

Electric Vehicle Charger Connection Unit

ARD-1-100TP

Installation Manual

V1.0 Oct 2021



Contents

Product Description	3
Warning Notice	3
Safety Advice	3
Introduction	4
Dimensions & Mounting the unit	5
Electrical Connections	7
Operating Instructions	9
Test Function	9
Specifications	10
Warranty	10
Declaration of Conformity	11

PRODUCT ADVISORY NOTICE

This product must be installed by a competent person in accordance with the IET Wiring Regulations, BS7671 (18th Edition or later) and current Building Regulations.

Ensure the electrical supply is disconnected before installation or removing the cover of the unit.

Product Description

The **matt:e** Electric Vehicle Charger Connection Units are designed for use in commercial applications where 3 phase PME supplies are feeding Electric Vehicle Chargers.

This manual covers the ARD-1-100TP unit.

The unit is not intended for any purpose other than that defined within this document.

WARNINGS

Please read and observe the following notices carefully. These warnings must be observed when installing and operating the Electric Vehicle Charger Connection Units.

All relevant supplies must be isolated or disconnected before commencing any work. This product must be installed by a competent person in accordance with the IET Wiring Regulations, BS7671 (18th Edition or later) and any relevant Building Regulations and/or Installation Regulations.



**Electrical
hazard**

Once installed, the unit has a Live Mains Supply (400v or higher) within the enclosure. The cover must not be removed until the supply to the unit has been isolated or disconnected.

Safety Advice

The unit must be installed in a dry ventilated location; it must never be covered or have restricted ventilation.

The ARD-1-100TP unit is rated for a maximum 100A.

For any information not contained within this document, please contact our technical support team on 01543 227290 or info@matt-e.co.uk.

Introduction

The **matt:e** range of Electric Vehicle Charger Connection Units are fitted with O-PEN technology designed to protect Electric Vehicle Charging equipment when installed onto 3 phase PME infrastructures.

The unit incorporates two 5 pole isolators with a built-in under-voltage release mechanism. On detection of fault conditions the O-PEN electronic circuit de-energises the under-voltage release mechanism which disconnects all poles of the supply including CPC. The 5 pole isolator will automatically reset after a PEN fault but must be manually reset after an overcurrent fault in line with IET Wiring Regulations and code of practice.

The **matt:e** O-PEN technology does not require earth rods or measuring electrodes to function correctly.

The units are designed to be installed indoors between the distribution board and the Electric Vehicle Charger. The unit must be mounted securely to a solid surface with the lid hinges on the left.

The installation location should be clean, dry and well ventilated.

Please refer to the diagrams on the following pages for the dimensions and mounting arrangement of the unit.



ARD-2-32x
ARD-3-32x
ARD-6-32x
ARD-1-32x-3-32x
ARD-1-100TP

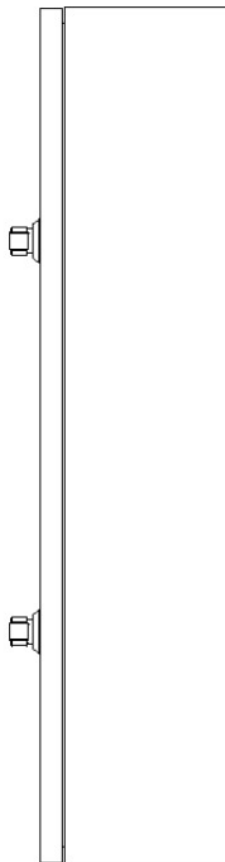
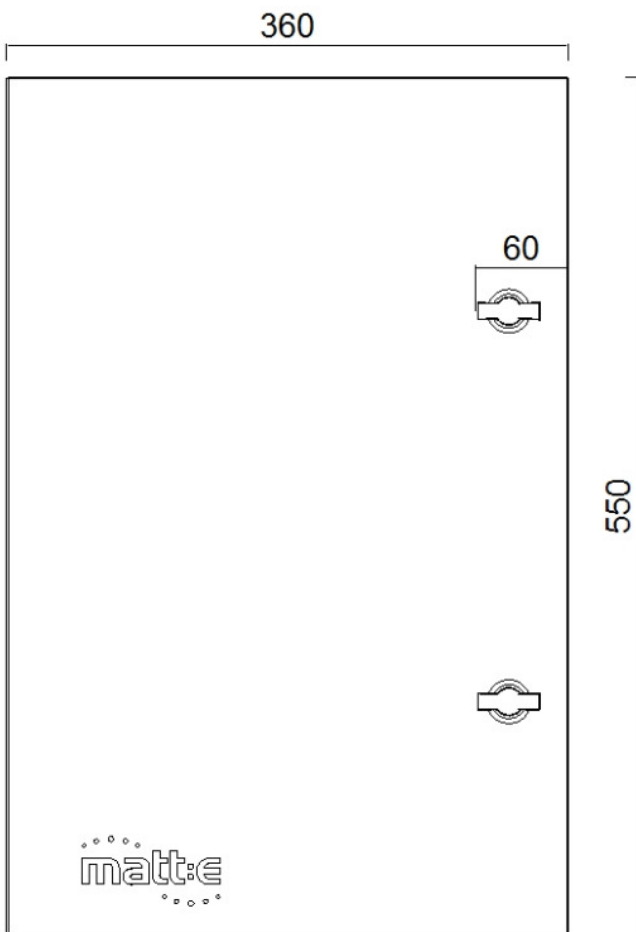

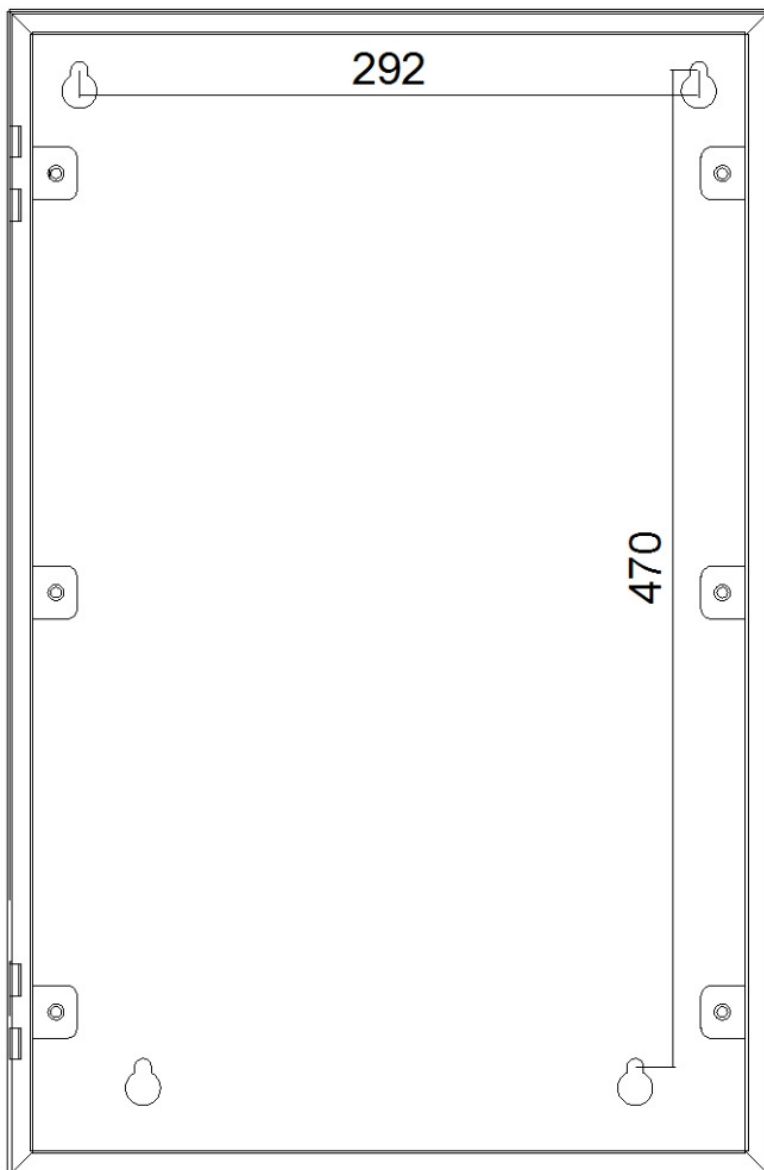

Mounting details

Electrical Connections

The user wiring connections are indicated in the diagrams below.

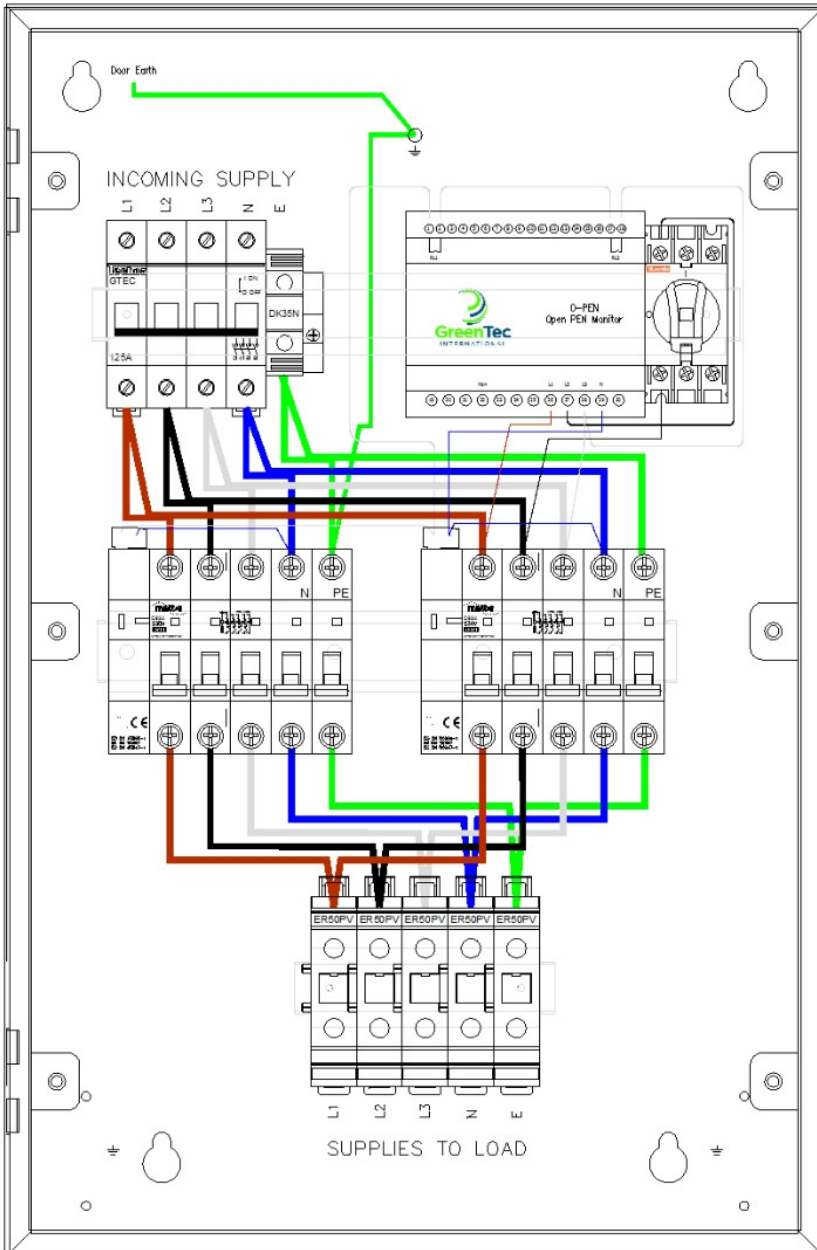

Connect the incoming cable from the distribution board directly to the 4 pole isolator. The CPC should be connected to the terminal block

Connect the outgoing cable and CPC to the terminal blocks.



Electrical
hazard

**THIS PRODUCT IS DESIGNED FOR AN ISOLATED
EARTHING ARRANGEMENT. CHECK BEFORE USING
SWA CABLE**

On completion of installation the tightness of all electrical connections should be checked before energising the unit.

See specifications for tightening torques.

Operating Instructions

With the incoming isolator closed the unit will monitor the incoming supply. If no fault condition is present approximately 1 second after closing the incoming isolator the O-PEN monitor will energise the under-voltage release mechanism of the 5 pole isolator (indicated by the green LED illuminating). At this point the 5 pole isolator can be closed to connect the load to the incoming supply. Alternatively wait 30 seconds and the isolator will automatically close.

In the event the O-PEN unit detects a fault condition on the monitored supply for a period of 4 seconds the internal relays will de-energise and remove the supply to the under-voltage release mechanism of the 5 pole isolator. This will cause the 5 pole isolator to open disconnecting all phases, neutral and CPC from the load.

Once the fault condition has cleared the O-PEN unit will reset after a 3 minute period and the 5 pole isolator will automatically reclose 30 seconds after.

Test Function



A Test Switch is provided to allow the functionality of the units to be checked. With the unit powered and the 5 pole isolator closed rotate the Test Switch anti-clockwise to position O to initiate a test. This will disconnect L1 from the O-PEN monitor and create a fault condition. After 0.7 seconds the O-PEN monitor will trip the 5 pole isolator by de-energising the under-voltage release mechanism.

Return the Test Switch to position I to clear the fault condition. The O-PEN unit will reset after 3 minutes.

We recommend the unit is tested on a 6 monthly basis.

Specifications

Description	Electric Vehicle Charger Connection Unit
Input (Volts)	Nominal input voltage 400v, 50Hz, 3 Phase AC
Max Load	100A
Dimensions (HxWxD)	550mm x 360mm x 140mm
Weight	Approximately 7 kg
Operating Temp	-5°C to +40°C
Enclosure	Mild Steel Powder Coated
Power Consumption	12VA
Ingress Protection	IP4X
Document Revision	V1.10 Oct 2021

Terminal Capacities	<u>Min</u>	<u>Max</u>
Incoming Isolator cable size & tightening torque	2.5 mm ² 1.5Nm	25.0mm ² 2Nm
Outgoing Terminals cable size & tightening torque	16 mm ² 5.6Nm	50mm ² 5.6Nm

Warranty

The ARD-1-100TP unit is guaranteed for a period of 1 year from the date of manufacture.

This warranty is limited to the replacement of faulty components only.

t: 01543 227290 e: info@matt-e.co.uk w: www.matt-e.co.uk

matt:e Ltd, Unit 5, Common Barn Farm, Tamworth Road, Lichfield WS14 9PX

EU Declaration of Conformity (DoC)

Ref : EVCC-32/63/100-2021

We

Company name: matt:e Ltd
 Postal address: Unit 5 Common Barn Farm Tamworth Road
 City: Lichfield
 Postcode: WS14 9PX
 Telephone number: 01543-227290
 E-Mail address: info@matt-e.co.uk

Declare that this DoC is issued under the sole responsibility of the manufacturer.

Apparatus model/Product: ARD-2-32x ARD-3-32x ARD-6-32x
 ARD-1-32x-3-32x ARD-1-100TP
 Type: EVCCU

Object of the declaration

Electric Vehicle Charger	ARD-2-32x ARD-3-32x ARD-6-32x
Connection units	ARD-1-32x-3-32x ARD-1-100TP

The object of the declaration described above is in conformity with the relevant Union harmonisation legislation:

Low Voltage Directive (2014/35/EU)

The following harmonised standards and technical specifications have been applied:

EN60255-1 2010 Emissions standard for Measuring Relays and Protection Equipment
 EN55011 Class A 2011 + A1:2017 Emissions Standard for ISM Equipment

EN60255-26 2013 Immunity standard for Measuring Relays and Protection Equipment,
 EN61000-4-2 2009 ESD Requirements
 EN61000-4-3 2006 + A1 + A2 Radiated Susceptibility
 EN61000-4-4 2012 Electrical Fast Transient Burst Requirement
 EN61000-4-5 2006 Surges Requirements
 EN61000-4-6 2009 Conducted Susceptibility
 EN61000-4-11 2004 Voltage Dips and Interruptions

EN61439-1&2 2011 Low-voltage switchgear and controlgear assemblies.
 EN60947 Low-voltage switchgear and controlgear
 EN60898-1 2019 Electrical accessories. Circuit-breakers for overcurrent protection
 EN50557 2011 Requirements for Automatic Reclosing
 EN61095 Electromechanical contactors
 EN61009-1 Residual current operated circuit-breakers with integral overcurrent

Signed for and on behalf of: **matt:e Ltd**

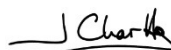

Place of issue
 Lichfield, England

Date
 Sept 2021

J Charlton, Director