



# Single-Phase IP65 Electric Vehicle Charger Protection Units

IP-EVCP-R(C)

## Installation Manual

Aug 2023

## Single-phase EV charger protection unit

### Contents

Product Description	3
Warning Notice	3
Safety Advice	3
Introduction	4
Dimensions & Mounting the unit	5
Touch Plate Assembly	6
Electrical Connections	7
Operating Instructions	9
Status Indicator	10
Specifications	11
Warranty	11
Declaration of Conformity	12

#### **PRODUCT ADVISORY NOTICE**

This product must be installed by a competent person in accordance with the IET Wiring Regulations, BS7671 (18<sup>th</sup> Edition or later) and current Building Regulations. Ensure the electrical supply is disconnected before installation or removing the cover of the Units.

## Single-phase EV charger protection unit

### Environment

**matt:e** no longer use plastic bags as part of product packaging. Wherever possible we utilise reusable biodegradable packaging for transportation. We ask that you support our efforts to reduce un-necessary waste and recycle all packaging appropriately. Thank you.

### Product Description

The **matt:e** Single Phase Electric Vehicle Charger Protection units are designed for use in domestic dwelling applications where single phase PME supplies are feeding Electric Vehicle Chargers. They should NOT be used on premises with 3 phase supplies.

This manual covers the IP-EVCP-R(C) models manufactured after August 2023.

The units are not intended for any purpose other than that defined within this document.

### Warnings

Please read and observe the following notices carefully. These warnings must be observed when installing and operating the Electric Vehicle Charger Protection units.

All relevant supplies must be isolated or disconnected before commencing any work. This product must be installed by a competent person in accordance with the IET Wiring Regulations, BS7671 (18<sup>th</sup> Edition or later) and any relevant Building Regulations and/or Installation Regulations.



Once installed, the unit has a Live Mains Supply (230v or higher) within the enclosure. The cover must not be removed until the supply to the unit has been isolated or disconnected.

### Safety Advice

The unit must be installed in a ventilated location out of direct sunlight.

The IP-EVCP units are rated for a maximum 32A.

For any information not contained within this document, please contact our technical support team on 01543 227290 or [info@matt-e.co.uk](mailto:info@matt-e.co.uk).

## Single-phase EV charger protection unit

### **Introduction**

The **matt:e** range of Single Phase Electric Vehicle Charger Protection units are designed to protect Electric Vehicle Charging equipment when installed onto single-phase PME infrastructures .

All units incorporate an electronic detection circuit and 3 pole contactor. The unit has a double pole Type A RCBO and a single terminal on the incoming side of the unit.

**The IP-EVCP-R(C) versions are rated to be connected directly to the supply meter tails via suitable connectors, or via the Consumer Distribution Board or 'Garage Board' and suitable protective device.**

The Current Curtailment versions are supplied with a split core CT for installing on the main incoming supply cable to the property. See page 7 for connection details.

On detection of fault conditions, the electronic circuit disconnects the EV charger from the incoming supply including CPC by de-energising the contactor. The isolation contactor is certified to BS EN 60947-4-1 and complies with the requirements of BS: 7671 18<sup>th</sup> Edition.

The **matt:e** IP-EVCP technology does not require earth rods or measuring electrodes to function correctly.

The units are designed to be installed between the service providers meter / distribution board and the Electric Vehicle Charger. The unit must be mounted securely to a solid surface with the lid hinges at the left.

**The installation location should well-ventilated and out of direct sunlight.**

Please refer to the diagrams on the following pages for the dimensions and mounting arrangements of the units.

# Single-phase EV charger protection unit

## Dimensions

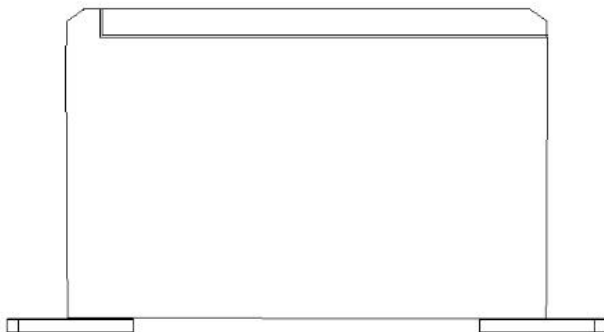
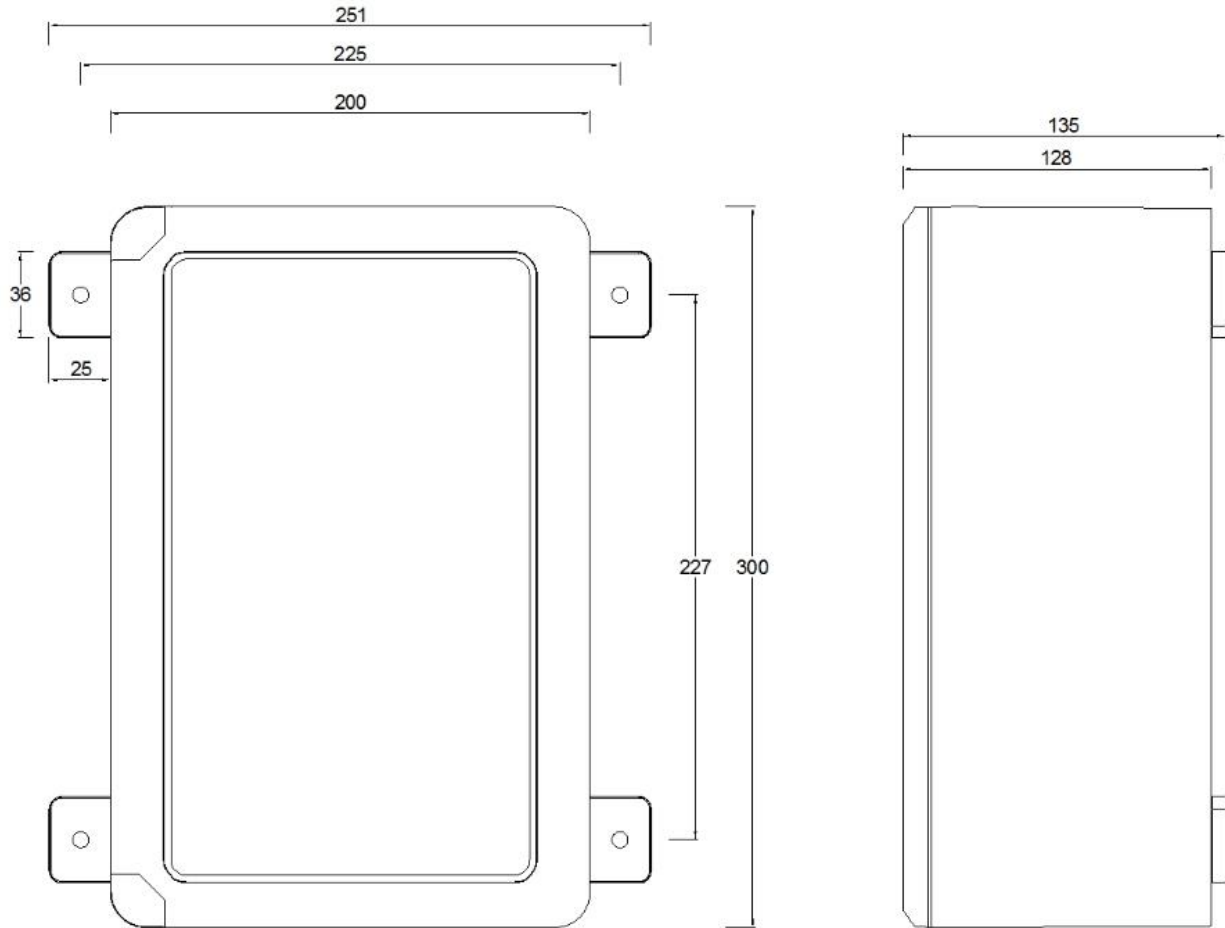

IP-EVCP-X (Cxx)

## Single-phase EV charger protection unit

### Touch Plate Assembly

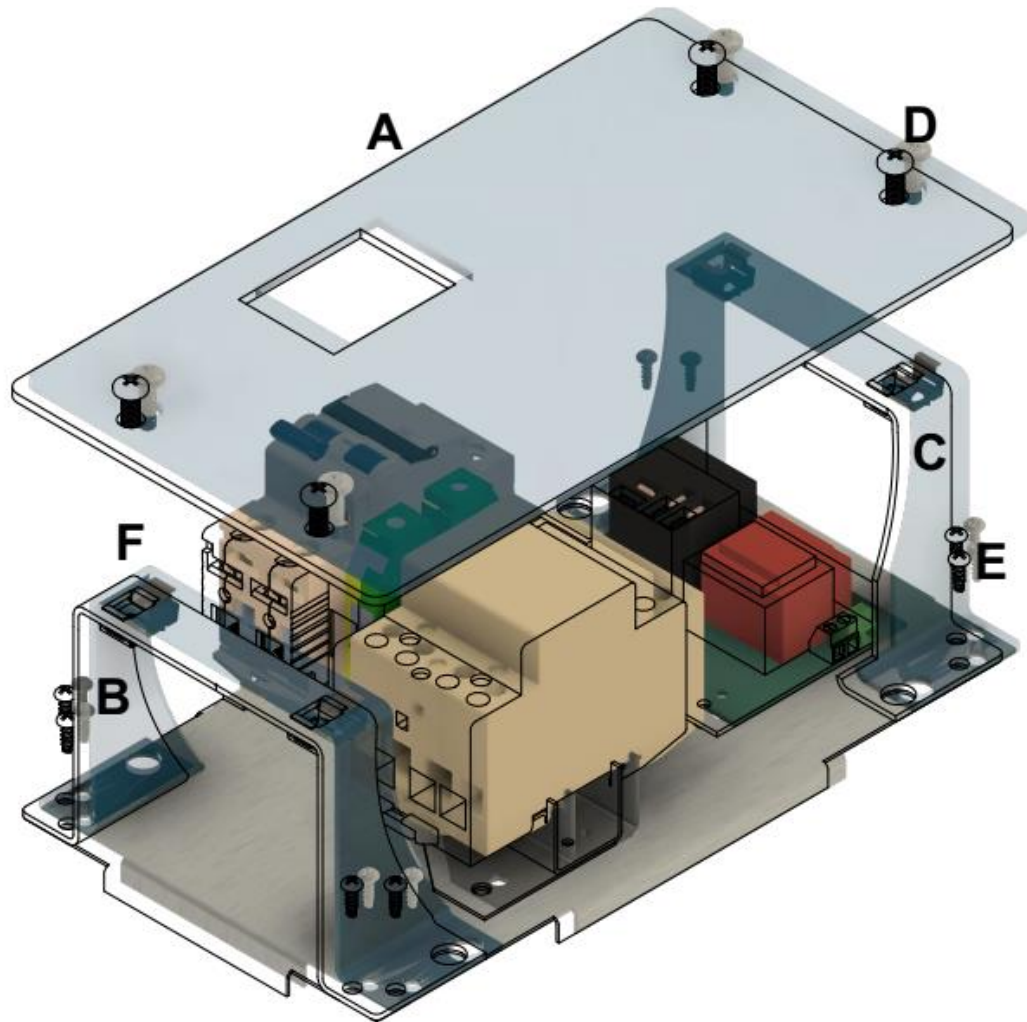

- A = Touch Plate
- B = Touch Plate Support
- C = Touch Plate Support With Cut Out
- D = 4 No. M5x12 Screws
- E = 8 No. 10x10mm Screws
- F = 4 No. M5 Cage Nut

## Single-phase EV charger protection unit

### Electrical Connections

#### IP-EVCP-R (C)

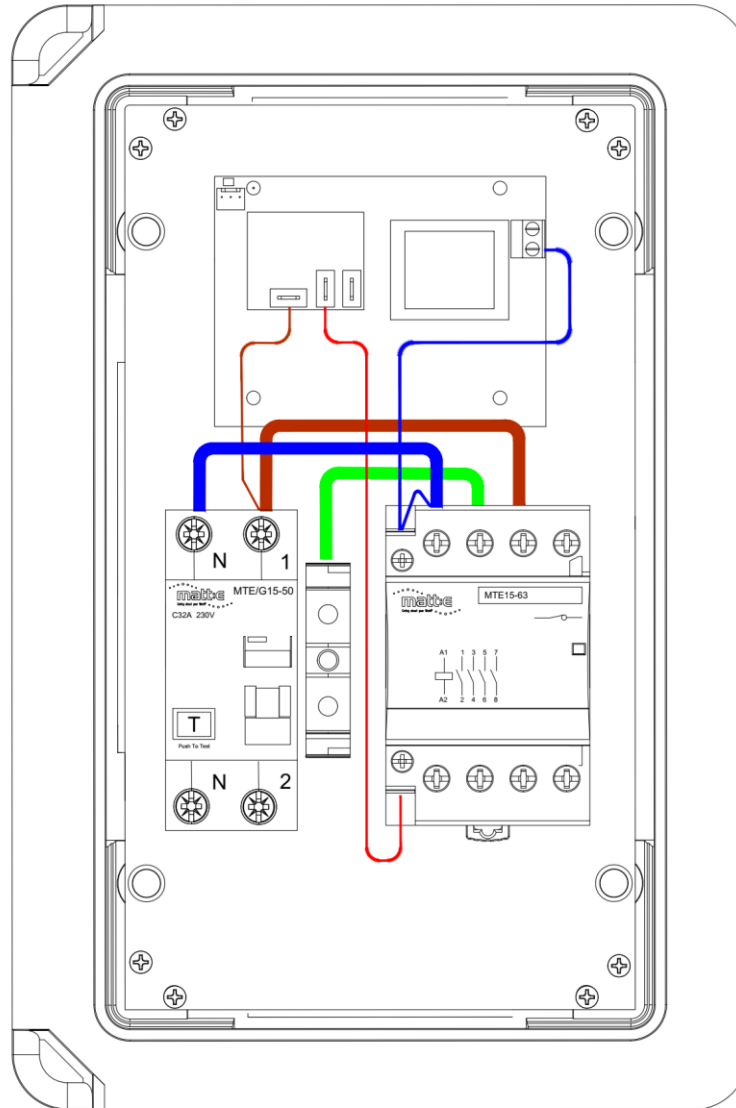

Connect the supply cable from the distribution board directly to the RCBO 'mains in' terminals. Connect the outgoing cable to the contactor N, E, & L terminals. If required, connect the CT to the 3 pin connector on the PCB. Check **ALL** power and earth connections before switching on.

**Please note: This product is designed for an isolated earthing arrangement. If in doubt please check before using SWA cable.**

### Single-phase EV charger protection unit

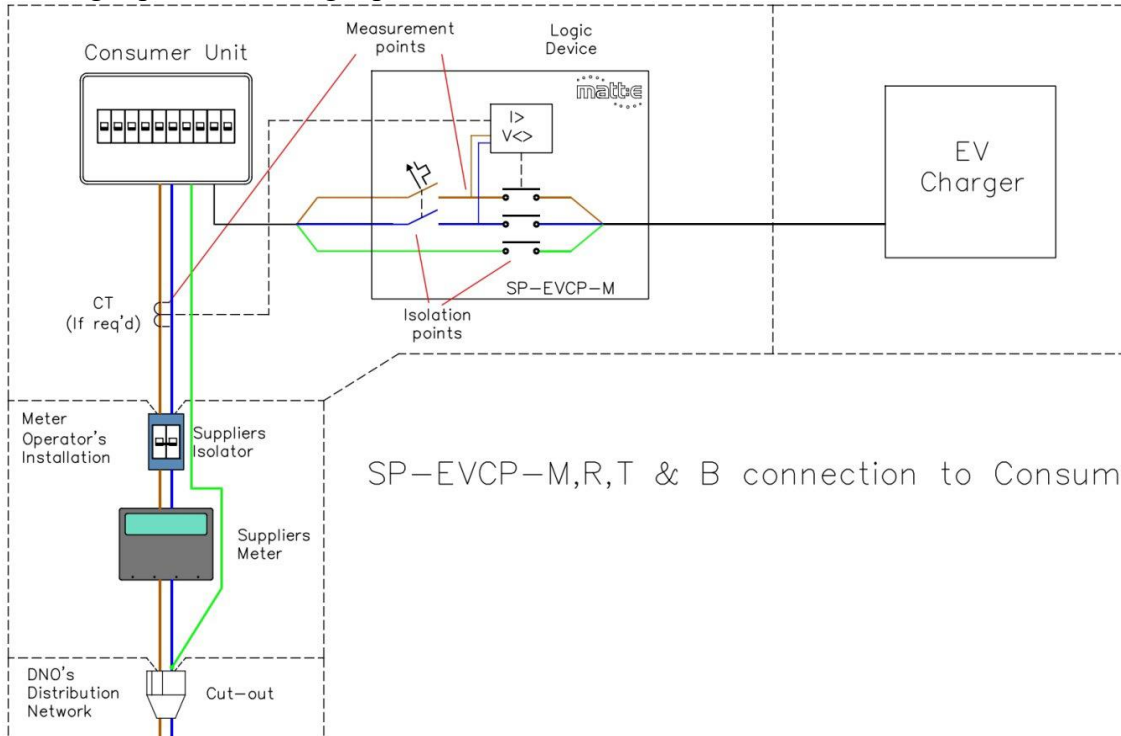

SP-EVCP-M,R,T & B connection to Consumer Unit

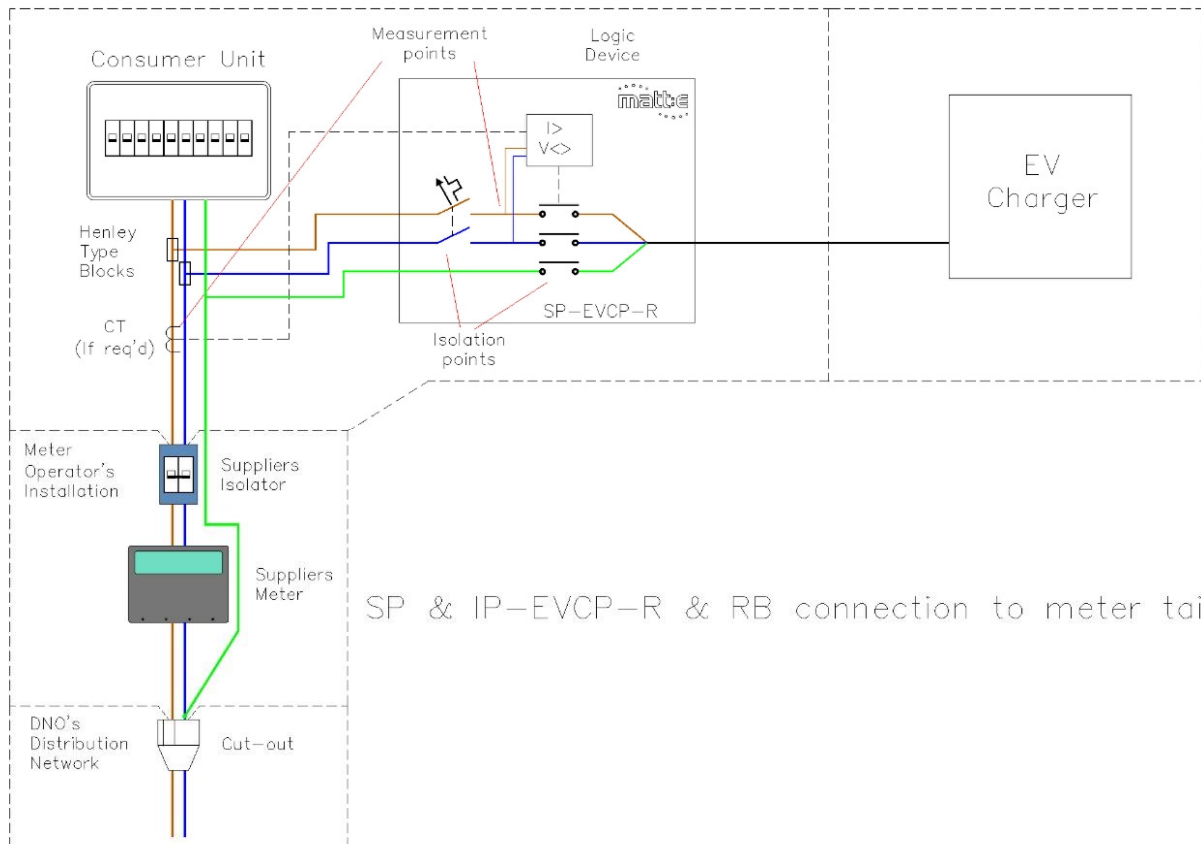

SP & IP-EVCP-R & RB connection to meter tails



## Single-phase EV charger protection unit

### Operating Instructions

With the supply switched on the electronic control circuit in unit will continuously monitor the incoming supply voltage.

If the incoming supply is within limits, approximately 5 seconds after switching on the contactor will energise and connect the load to the incoming supply and the CPC. The 5 second delay is to establish the incoming supply is stable before applying power to the load.

In the event the IP-EVCP-R(C) unit detects a fault condition on the monitored supply for a period of 4 seconds, the electronic control circuit will de-energise the contactor coil which will open the contactor disconnecting Line, Neutral and CPC from the load.

The contactor will remain de-energised until the monitored supply has returned to the correct level and remained stable for a period of 3 minutes.

The current monitoring versions are supplied with a split core CT to allow the unit to monitor whole house load. The CT should be clamped around the incoming supply cable directly after the service providers' meter. It is designed to measure the FULL load current to the house. Connection diagrams are shown from page 9.

The current monitor versions of the IP-EVCP-R(C) have a current curtailment function designed to prevent the domestic load exceeding the deemed Domestic Load Level. The current must be factory set. **All** versions function in the same way.

The total current of the incoming mains supply is measured by the CT.

Normal operational state – If the measured current demand exceeds the Domestic Load Level for 4 seconds the supply to the EV charger is disconnected by de-energising contactor C1. The new value of the current demand is noted by the processor 1 second after C1 has been de-energised.

Once the measured current demand has reduced to a value where the current required by the car charger will not cause the current demand to exceed the deemed Domestic Load Level for a period of 3 minutes the EV charger supply is reinstated by energising C1.

## Single-phase EV charger protection unit

### LED Status Indicator

A dual colour (Red / Green) LED gives a visual indication of the real time status of the unit.

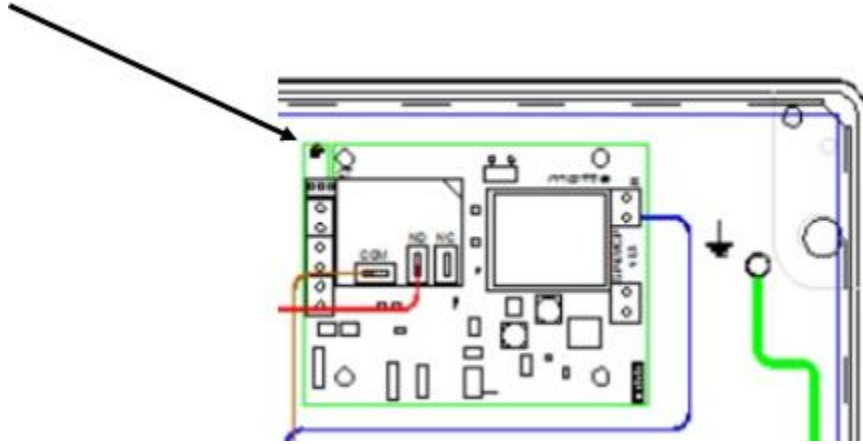

### LED flash codes

Version info	Software Ver. 1.2	1 red flash (major) followed by 2 green flashes (minor), this appears once at power on during the first 5 secs of operation
Normal operation	No errors	Green flashes continuously @ 1Hz
Tripped	Over current	Alternating green and red flashes @ 1Hz – recovers when current in range
Tripped	Under voltage	1 red flash over 4 sec period – recovers when voltage in range
Tripped	Over voltage	2 red flashes over 4 sec period – recovers when voltage in range
Tripped	DC Detected	3 red flashes over 4 sec period – power cycle / engineer attention
Tripped	CT not found	4 red flashes over 4 sec period – power cycle / engineer attention
Tripped	Internal error	Solid red – power cycle required – power cycle / engineer attention
Normal operation	Voltage error state commencing	Red flashes continuously @ 2Hz
Normal operation	Voltage error state recovering	Green flashes continuously @ 2Hz

**Specifications**

Description	Electric Vehicle Charger Protection Unit		
Input (volts)	230V 50Hz		
Max Load	32A – all units		
Dimensions (H x W x D)	300mm x 200mm x 129mm		
Operating Temperature	-5°C to +40°C		
Storage Temperature	-5°C to +40°C		
Enclosure	ABS-HB Flame retardant plastic		
Ingress Protection	IP65		
Impact resistance	IK08		
Power Consumption	13VA		
The Rated impulse withstand voltage (uimp)	6KA		
The rated short-time withstand current (Icw)	10KA		
The rated conditional short-circuit current (Icc)	25KA		
Pollution degree	4		
Types of earthing systems	TN-S, TN-C-S		
Designed for use in non-restricted locations			
Document Revision	August 2023		
Terminal Capacities	Min	Max	Torque
Supply E terminal cable size and tightening torque	2.5mm	16mm	2.5Nm
Supply RCBO cable size and tightening torque	4mm	25mm	3Nm
Load contactor cable size and tightening torque	4mm	10mm	3.5Nm

WARNING: This equipment is compliant with Class A of EN55032. In a residential environment this equipment may cause radio interference.

**Warranty**

The IP-EVCP-R(C) units are guaranteed for a period of 3 years from the date of manufacture. This warranty is limited to the replacement of faulty components only.  
 t: 01543 227290 e: info@matt-e.co.uk w: [www.matt-e.co.uk](http://www.matt-e.co.uk)

matt:e Ltd, Unit 1, Langley Brook Business Park, Middleton, Tamworth, B78 2BP

Single-phase EV charger protection unit

Company name: matt:e Ltd

**EU Declaration of Conformity (DoC)**

Ref: IP-EVCP-R 2023

**We**

Company name: matt:e Ltd  
 Postal address: Unit 1 Langley Brook Business Park  
 City: Middleton, Tamworth  
 Postcode: B78 2BP  
 Telephone number: 01543-227290  
 E-Mail address: info@matt-e.co.uk

**Declare that this DoC is issued under the sole responsibility of the manufacturer.**

Apparatus model/Product: IP-EVCP-R(C)  
 Type: Single-phase electric vehicle charger protection

**Object of the declaration**

Electric Vehicle Charger	IP-EVCP-R(C)
Connection units	

**The object of the declaration described above is in conformity with the relevant Union harmonisation legislation:**

Low Voltage Directive (2014/35/EU)

**The following harmonised standards and technical specifications have been applied:**

EN60255-1 2010 Emissions standard for Measuring Relays and Protection Equipment  
 EN55011 Class A 2011 + A1:2017 Emissions Standard for ISM Equipment

EN60255-26 2013 Immunity standard for Measuring Relays and Protection Equipment,  
 EN61000-4-2 2009 ESD Requirements  
 EN61000-4-3 2006 + A1 + A2 Radiated Susceptibility  
 EN61000-4-4 2012 Electrical Fast Transient Burst Requirement  
 EN61000-4-5 2006 Surges Requirements  
 EN61000-4-6 2009 Conducted Susceptibility  
 EN61000-4-11 2004 Voltage Dips and Interruptions

EN61439-1&2 2011 Low-voltage switchgear and control gear assemblies.  
 EN60947-3 Low-voltage switchgear and control gear  
 EN61095 Electromechanical contactors  
 EN61009-1 Residual current operated circuit-breakers with integral overcurrent

**Signed for and on behalf of: matt:e Ltd**

**Place of issue**

**Date**

Tamworth, England

August 2023



R Winter, Director